



a xylem brand

## 28320 SERIES FLEX IMPELLER HYGIENIC STAINLESS STEEL MOTOR PUMP UNITS (P80 size)

### FEATURES:

- Self primes from dry up to 3.5 metres
- Flows up to 74 litres per minute
- Pressures up to 1.7 bar. (*Pressures over 1.7 bar will reduce shaft life*)
- Handles soft solids up to 12mm diameter
- FDA Materials Certified
- Clean-In-Place (CIP) or easy strip clean
- Maximum viscosity:
  - 4 pole motor approx 150cP
  - 6 pole motor approx 700cP
- Low shear design

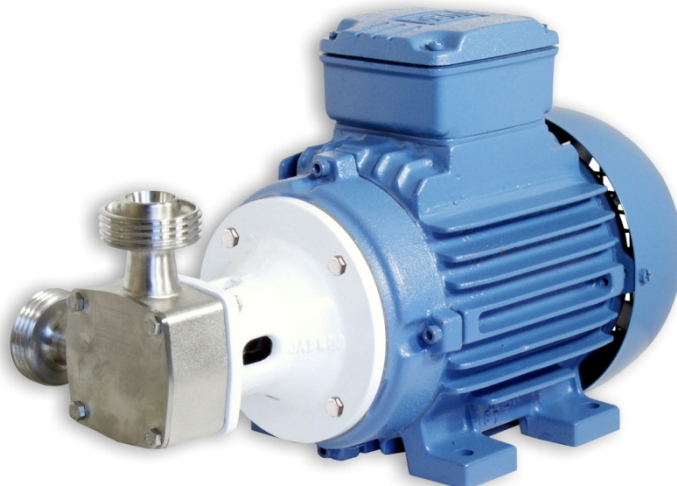

### PUMP PERFORMANCE:

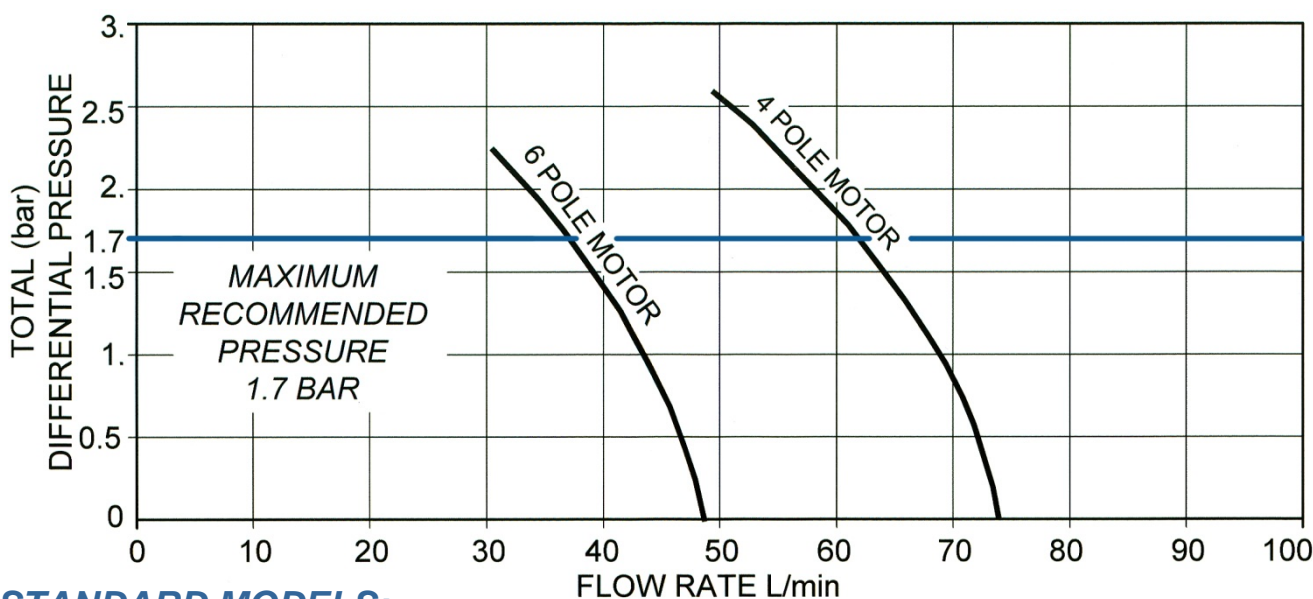

### STANDARD MODELS:

MODEL	IMPELLER	PORTS	SEAL	MOTOR	SPEED	POWER
<b>28320-4105C</b>	3A Neoprene	1" RJT	Carbon / Ceramic	230/1/50Hz	4 pole	0.55kW
<b>28320-4105L</b>	3A Neoprene	1" RJT	Carbon / Ceramic	230/1/50Hz	6 pole	0.37kW
<b>28320-4105E</b>	3A Neoprene	1" RJT	Carbon / Ceramic	230-400/3/50Hz	6 pole	0.55kW
<b>28320-4105H</b>	3A Neoprene	1" RJT	Carbon / Ceramic	230-400/3/50Hz	4 pole	0.55kW

**Other hygienic ports available:** Tri-clamp, IDF/ISS, 3A Bevel seat, DIN11851, and SMS 1145

**IMPELLER TEMPERATURE RANGE:**

<b>ELASTOMER OPTION</b>	3A Neoprene	E.P.D.M.
<b>TEMPERATURE RANGE</b>	4°C to 65°C	4°C to 90°C

**SPECIFICATIONS:**

<b>SEAL OPTIONS:</b>	Carbon / ceramic mechanical face seal (standard). Tungsten carbide / ceramic hard faced seal Flushed options for crystallising fluids
<b>SEAL ELASTOMER:</b>	Food grade nitrile
<b>PUMP HEAD:</b>	Stainless steel 316, machined interior and electro polished exterior finish
<b>END COVER:</b>	Stainless steel 316 grade
<b>SHAFT:</b>	Stainless steel 316 grade
<b>MOTOR:</b>	TEFV & IP55
<b>MOTOR ADAPTOR:</b>	Epoxy coated cast iron

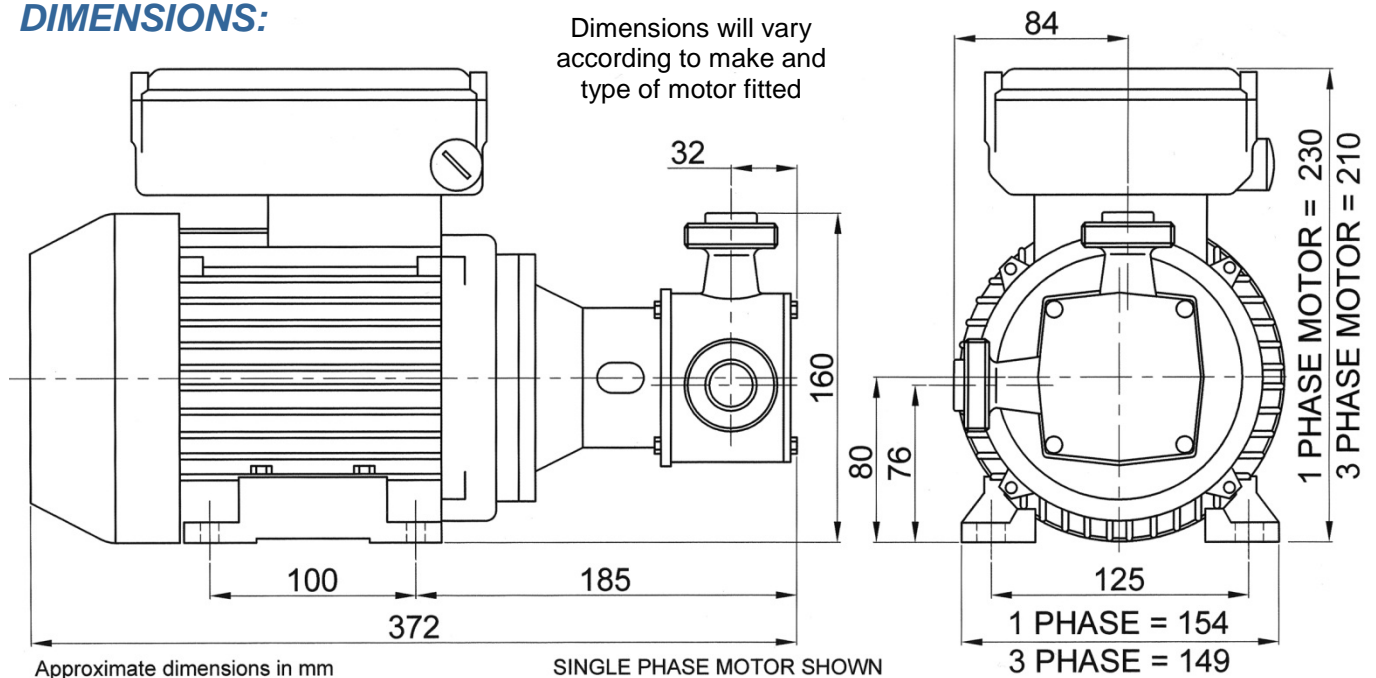
**DIMENSIONS:**

**WARNING**

Explosive hazard. **DO NOT** pump petrol, solvents, thinners or other flammable liquids with a flash point below 37°C (98°F)